



lighting

www.gruponovolux.com

Instrucciones Instructions

KRYSTAL

511A-L0103H-29

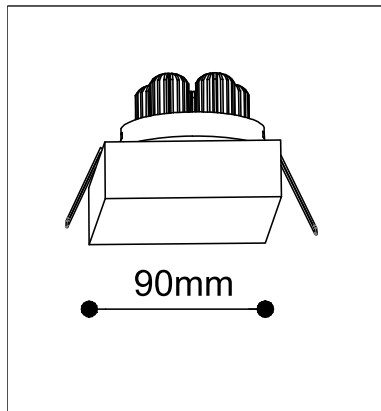

Need LED driver 350mA constant current
Voltage range including DC 8-11V

WARNING: CONNECT IN SERIES ONLY
IN ORDER TO KEEP A CONSTANT CURRENT.

1.

2.

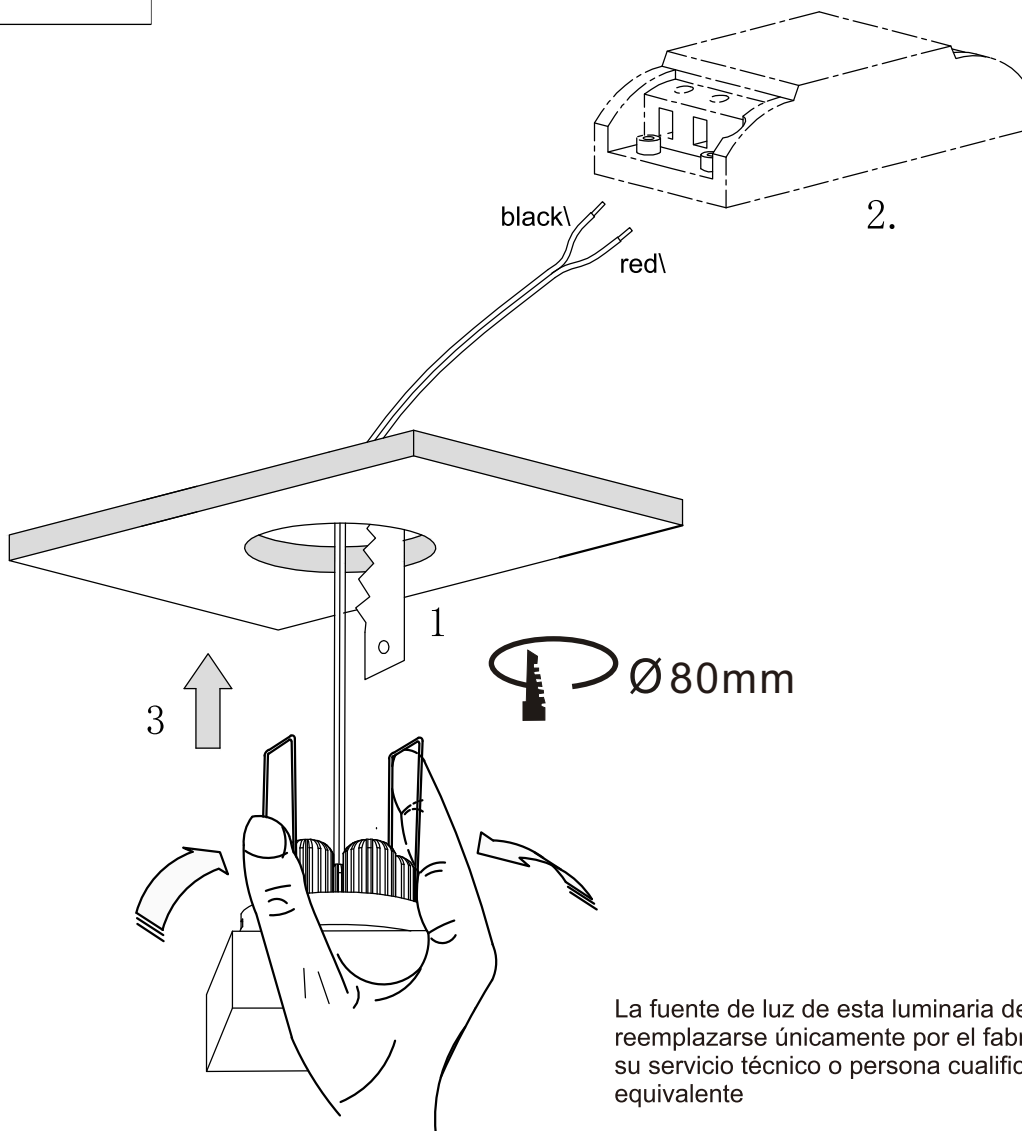

La fuente de luz de esta luminaria debe reemplazarse únicamente por el fabricante, su servicio técnico o persona cualificada equivalente

The source of light of this luminaire must be replaced by the manufacturer, the technical service or an equivalent qualified person.

La source lumineuse de cette lumière doit être remplacée que par le fabricant, son service technique ou une personne qualifiée équivalente

GRUPO GESTION INTEGRAL NOVOLUX INTERNACIONAL, S.L.
 C/Ramon Berenguer, 8 (poligono Industrial Can Vinyals)
 08130 Sta. perpetua de Mogoda-BARCELONA-Espana
 ESPANA-PORTUGAL: Tel+34 93 274 52 52
 FRANCE: Tel 0800 918 906
 REST OF THE WORLD: Tel+34 93 516 20 05
 Fax +34 933 463 751/933 114 546 - info@gruponovolux.com